

SRM-155

SONET/SDH Fiber-Optic Receiver Module with SAW Filter Clock Recovery and Data Retiming



The SRM-155 SONET/SDH Fiber-Optic Receiver Module

Features

- SONET OC-3 and SDH STM-1 Compatible
- SAW Filter Clock Recovery and Data Retiming
- 17 ps Typical Output Jitter
- PECL Clock and Data Outputs
- Single +5 Volt Supply
- CMOS Loss of Signal Flag
- Operation at 1300 nm and 1550 nm
- -45° to +85°C Operation
- Wide Dynamic Range
- Multi-Sourced 20 Pin DIL Footprint

Applications

- Telecom Receiver Applications
Medium and Long Haul SONET/SDH @ 155 Mb/s
- High Performance Datacom Receiver Applications
ATM @ 155 Mb/s

Description

VTI's SRM-155 is a fully integrated fiber-optic receiver module with SAW filter clock recovery and data retiming. It is ideally suited for SONET OC-3, SDH STM-1 and other 155 Mb/s fiber-optic transmission applications that demand superior performance and stability.

SRM-155 SONET/SDH Receiver Module

Product Data Sheet

Functional Overview

This highly integrated module converts a 155 Mb/s fiber-optic NRZ signal to differential PECL recovered clock and retimed data outputs. A CMOS flag alerts the user to a loss of signal condition when the optical input falls below an acceptable level.

A single +5 Volt supply provides bias for the module's pin-photodiode, preamplifier, Quantizer, and SAW filter timing recovery circuit. All elements are integrated into fiber-coupled 1.3" X 0.635" 20 pin DIL package. The SRM-155 footprint and pinout are industry common for ease of integration.

The optical signal is coupled through a short length of SBJ, Type 2, 62.5 μm multimode optical fiber to a hermetic module which encases an InGaAs pin-photodiode and preamplifier. The pin-photodiode converts the optical signal to an electrical current. The signal is then converted to a voltage and amplified by a low noise transimpedance amplifier. Further gain is provided by the quantizer, which also provides a Flag output when the optical signal falls below an acceptable

level. The signal is then input to a SAW-filter timing recovery circuit where the the clock signal is recovered, and the data signal is reshaped and retimed.

The clock recovery and data retiming function is achieved using a SAW filter technique which is well established and proven through years of application in high performance telecom systems.

The clock is extracted from the input NRZ data by first passing it through a frequency doubler to generate sufficient spectral energy at 155 MHz. The SAW filter, a precision narrow band filter, then suppresses jitter by rejecting unwanted frequency spectrum. The extracted clock is then precisely aligned with the data and the signals are reshaped.

The output signal is thus free of undesirable jitter and distortion. Unlike phase-locked loop designs, the jitter transfer function of the SRM-155's timing recovery circuit is uniquely stable because it is determined by the shape of the SAW filter's response, which can be precisely controlled. In addition to low output jitter and excellent stability, the SRM-155's timing recovery circuit exhibits fast acquisition time and robust operation

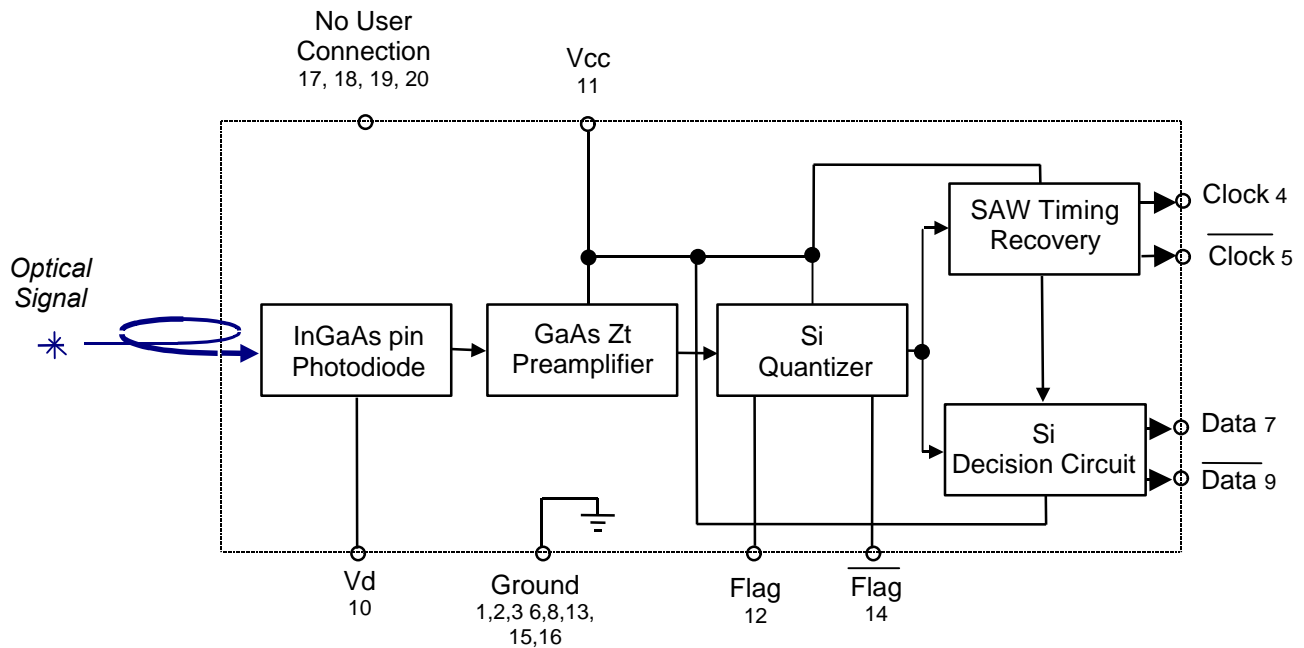

Figure 1. SRM-155 Functional Block Diagram

SRM-155 SONET/SDH Receiver Module

Product Data Sheet

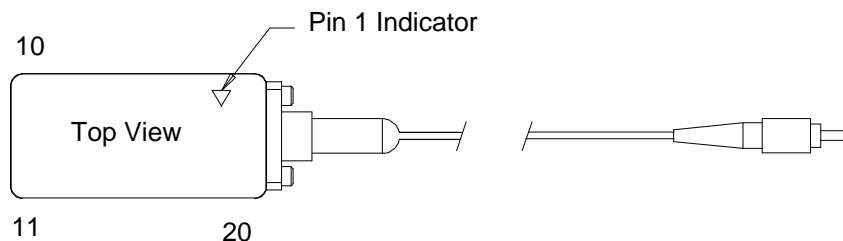

Figure 2. Pin Diagram (Top View)

Table 1. Pin Function

Pin	Symbol	Function
4	<u>Clock</u>	PECL Recovered Clock Output.
5	<u>Clock</u>	PECL Complementary Recovered Clock Output.
7	<u>Data</u>	PECL Retimed Data Output.
9	<u>Data</u>	PECL Complementary Retimed Data Output.
10	V_D	Detector Anode Bias. Ground or apply +5 Volt bias through a series resistor for received optical power monitoring. ¹
11	V_{CC}	5 Volt Supply Voltage.
12	<u>Flag</u>	Input Signal Level Status. This CMOS output switches low when the received optical power falls below the status minimum optical power level.
14	<u>Flag</u>	Complementary Input Signal Status. CMOS complement of Flag.
1,2,3,6,8,13,15,16	GND	Ground.
17,18,19,20	NC	No User Connection.

1. By connecting pin 10 to a +5 Volt bias through a series resistor (eg. 1 k Ω) received optical power can be monitored as a voltage drop across the resistor.

Absolute Maximum Ratings

Absolute maximum ratings are provided here as worst case and short duration exposure conditions only. Exposure to conditions more severe than the Absolute Maximum Ratings may result in permanent damage. Exposure to conditions at the Absolute

Maximum Ratings for extended periods may also adversely affect device performance or reliability. Functional operation of the device is not implied at these conditions.

Table 2. Absolute Maximum Ratings

Parameter	Symbol	Minimum	Maximum	Units
Storage Temperature Range	T_s	-40	85	$^{\circ}\text{C}$
Supply Voltage	V_{CC}	0	+6	V
pin Detector Bias	V_D	0	+6	V
Lead Soldering Conditions			250/10	$^{\circ}\text{C/s}$

SRM-155 SONET/SDH Receiver Module

Product Data Sheet

Performance Characteristics

Table 2. Electrical Performance

Parameter	Symbol	Minimum	Typical	Maximum	Units
Input Signal Rate ¹	f_o	155.489	155.520	155.551	Mb/s
Operating Temperature	T_o	-40		+85	°C
Power Supply Voltage	V_{CC}	4.5	5.0	5.5	V
pin Detector Bias Voltage (pin10)	V_D	0	0	+5	V
Power Supply Current	I_{CC}			300	mA
Data and Clock Output Levels ²					
Low	V_{OL}	$V_{CC} - 1.95$		$V_{CC} - 1.63$	V
High	V_{OH}	$V_{CC} - 1.03$		$V_{CC} - 0.88$	V
Clock to Data Alignment ³	T_{CDA}	-100		+100	ps
Data and Clock Output Rise and Fall Times ⁴	T_R, T_F	275	375	575	ps
Output Clock Duty Cycle	Duty	45	50	55	%
Received Power Level Flag	LOS				
Decreasing Optical Power			-37		dBm
Increasing Optical Power			-34		dBm
Flag Hysteresis	Hyst		3		dB
Acquisition Time ⁵	T_A			2	μs
Output Clock Random Jitter ⁶	J_C		17		ps rms

1. Other center frequencies are available in the 124 to 622 MHz frequency range. Please contact t VTI for further details.

2. Measured with a load of $R_L = 50\Omega$ to $V_{CC} - 2 V$. See figures 3 and 4. ECL levels are specified for dc measurement, an additional tolerance of 50 mV should be included for dynamic measurements.

3. Alignment of clock and data outputs (see Figure 5.).

4. Measured at 20% to 80% levels.

5. Time required to achieve valid data and clock outputs with a transition density of at least 50%.

6. Measured with an input data pseudorandom word $2^{23} - 1$.

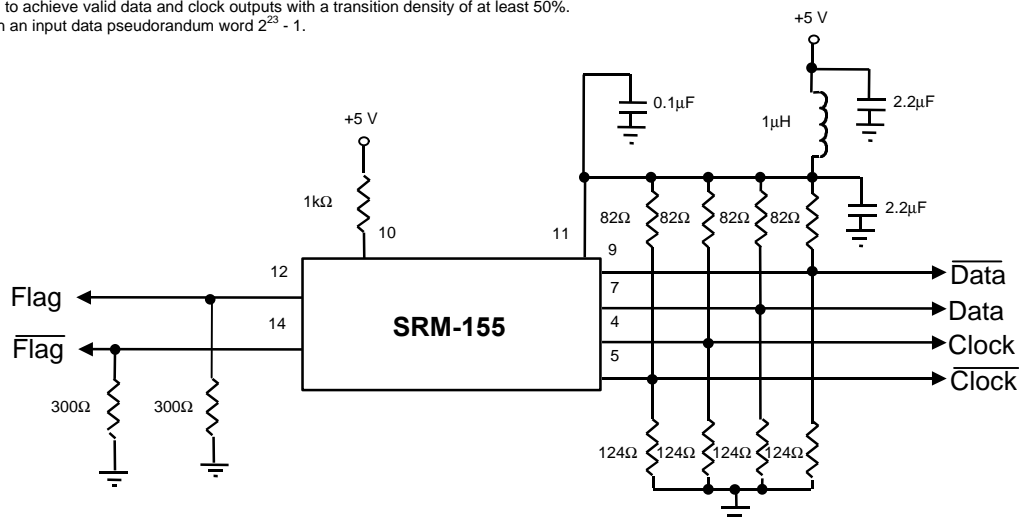

Figure 3. PECL Interface

SRM-155 SONET/SDH Receiver Module

Product Data Sheet

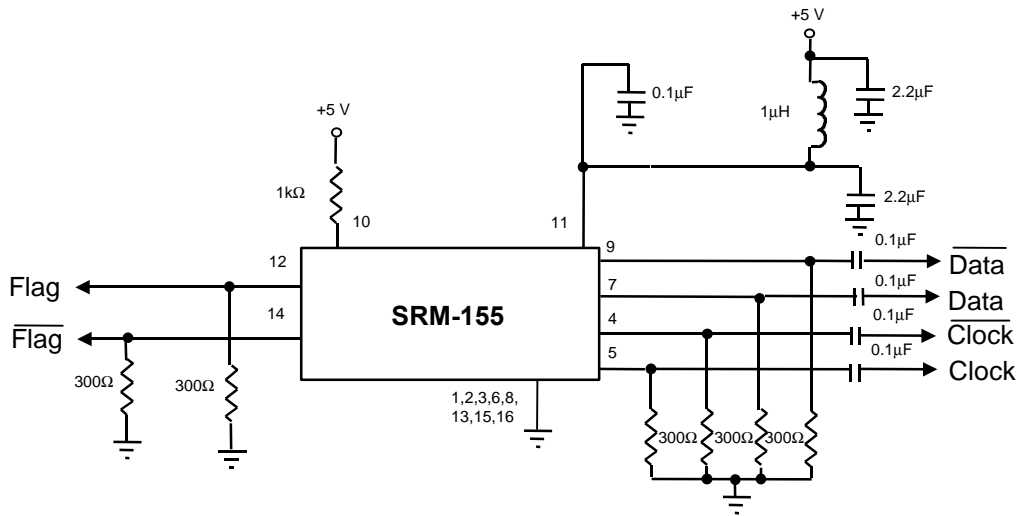

Figure 4. ECL (AC Coupled) Interface

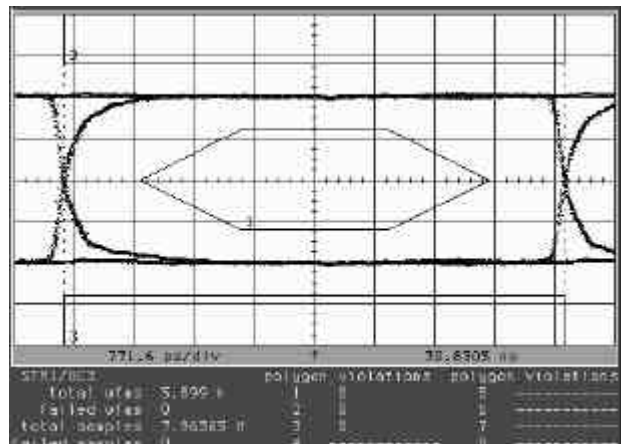
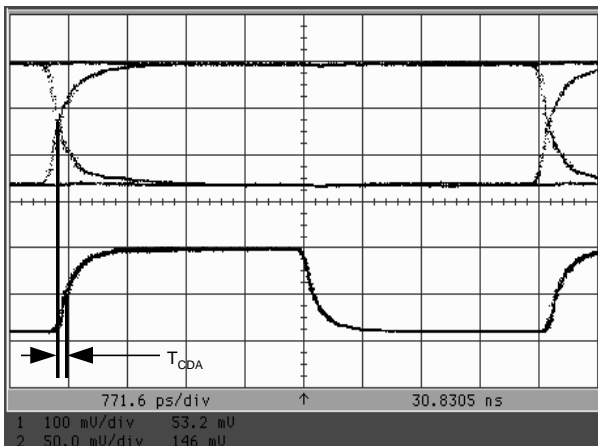

Figure 5. Typical Performance

Table 3. Optical Performance

Parameter	Symbol	Minimum	Typical	Maximum	Units
Minimum Average Sensitivity ¹	Sens.			-34.0	dBm
Maximum Optical Input ¹	P _{MAX}	0			dBm
Input Wavelength	λ	1100		1580	nm

1. For a BER less than 1E-10. Measured using a 2²³-1 pseudorandom word and a 50% average optical duty cycle and a 10 dB Extinction Ratio.

SRM-155 SONET/SDH Receiver Module

Product Data Sheet

Qualification

The SRM-155 has been designed to comply with the intent of Bellcore specifications TR-NWT-000468 and TA-TSSY-000983 and will be subject to a complete qualification test plan to demonstrate full compliance. All of the technologies used in the assembly of the module represent standard microelectronics technologies that are used in similar products, and have extensive field reliability data.

While all components and technologies used in the optical receiver are backed by qualification data and should present no reliability risk, VTI intends to qualify the fully assembled module with the final design. The qualification plan will entail mechanical and environmental tests along with accelerated life tests. The tests will include those parameters listed below.

Table 4. Qualification Plan

Parameter	Test Method	Sample Size
Physical Dimensions	MIL-STD-883, Method 2016	11
Mechanical Shock	MIL-STD-883, Method 2007, Test B	11
Vibration, variable frequency	MIL-STD-883, Method 2007, Test A	11
Lead Solderability	MIL-STD-883, Method 2003	22
Lead Integrity	MIL-STD-883, Method 2004	15
Temperature Cycling	-40°C/85°C, 300 cycles	11
High Temperature Aging	85°C under bias, 3000 hours	11
Low Temperature Storage	-40°C, 168 hours	11
ESD	Method 3015	3
Destructive Bond Pull	MIL-STD-883	40

Optical Fiber Characteristics

The fiber pigtail is a 30.0 +/-1 inch (measured from the package case to the connector tip) Type 2A multimode fiber with a 62.5 um core. The fiber is encased in a slate colored Strengthened Buffered

Jacket (SBJ) cable sheath having a 900 um outer jacket diameter. The minimum fiber bend radius is 1.25 inches. Connectors may be selected to meet the specific requirements of each application.

SRM-155 SONET/SDH Receiver Module

Product Data Sheet

Outline Diagram

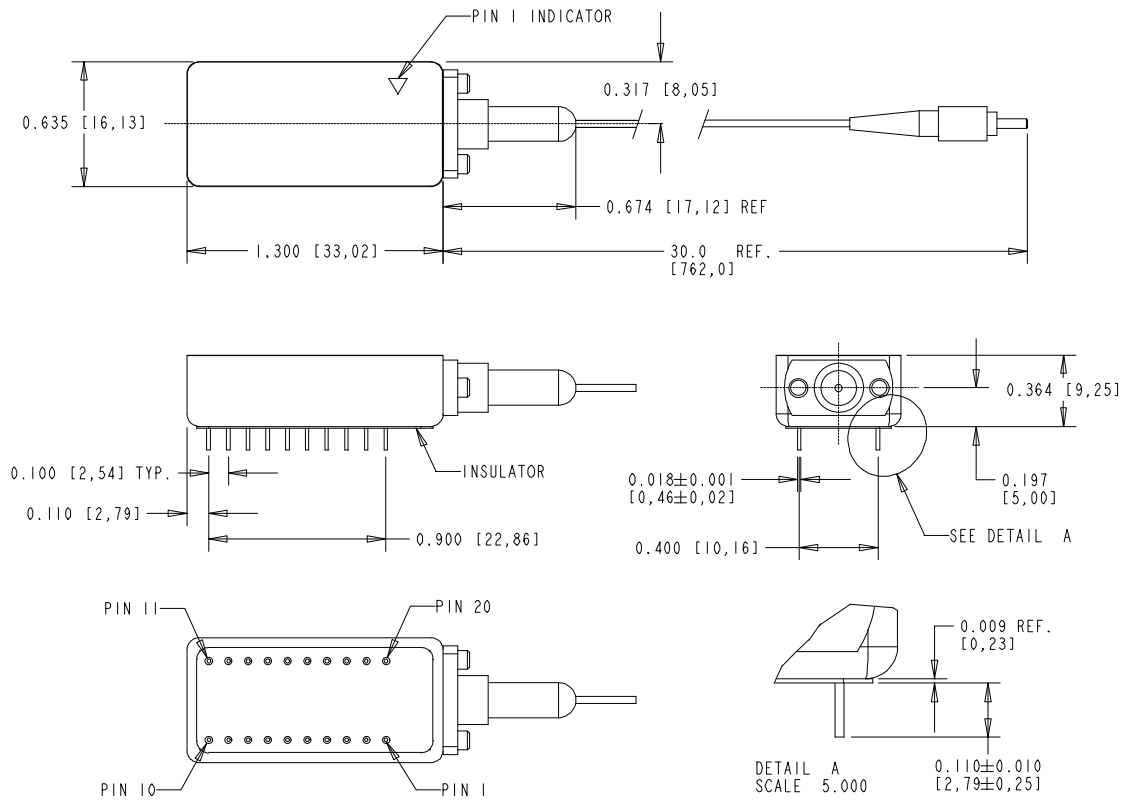

Figure 5. Outline Diagram

Ordering Information

Table 5. Part Numbers

Fiber-Optic Connector ¹	Model Number	VTI Code Number
None	SRM-155	330001595
FC/PC	SRM-155A	330001702
ST	SRM-155B	330001710
SC	SRM-155C	330001728

1. Other connectors or fiber requirements are available to meet specific application requirements.

SRM-155 SONET/SDH Receiver Module

Product Data Sheet

Notes:



For Additional Information Please Contact:

Vectron Technologies, Inc.
267 Lowell Road
Hudson, NH 03051
Tel: (603) 598-0070 Fax: (603) 598-0075

Vectron Technologies, Inc. reserves the right to make changes to the product(s) and/or information contained herein without notice. No liability is assumed as a result of their use or application. No rights under any patent accompany the sale of any such product(s) or information.

Rev. 0.1, 3/14/97 MDC, /SRM155F2.SD